

ELBOW 弯头

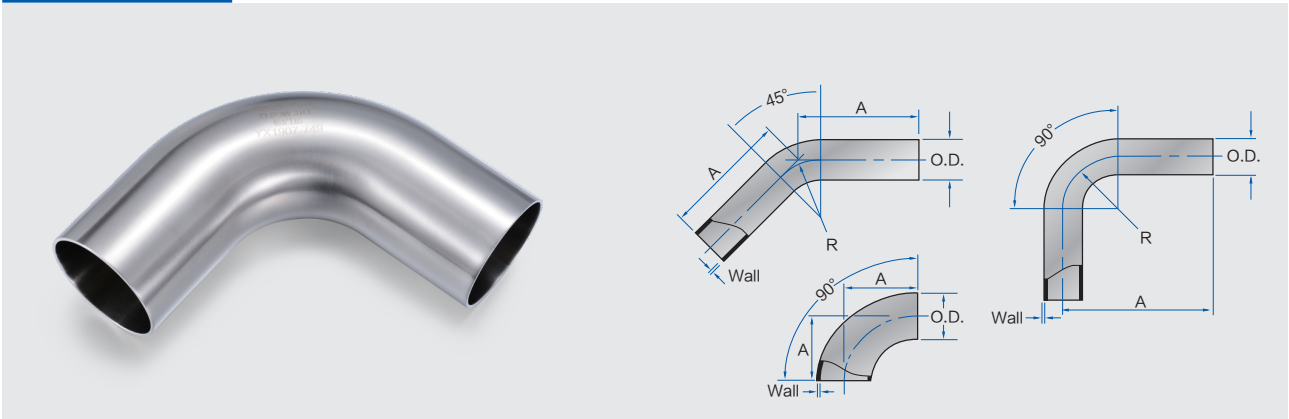

Pipe Size (A Size) 90°

Unit : mm

Size	8A	10A	15A	20A	25A	32A	40A	50A	65A
R	25.4	25.4	38.1	38.1	38.1	47.6	57.2	76.2	95.3
A	55.0	62.0	75.0	75.0	75.0	94.0	104.0	123.0	147.0
Size	80A	100A	125A	150A	200A	250A	300A	350A	400A
R	114.3	152.4	190.5	228.6	304.8	381.0	457.2	533.4	609.6
A	166.0	204.0	250.0	290.0	375.0	381.0	457.2	613.0	690.0

Tube Size (Inch Size) 90°

Size	1/4"	3/8"	1/2"	3/4"	1"	1-1/2"	2"	2-1/2"	3"	4"	6"
R	20	23	25	30	33	57.2	76.2	95.3	95.3	133.4	228.6
A	49	52	54	66	69	104	123	147	147	185	290

Pipe Size (A Size) 45°

Size	8A	10A	15A	20A	25A	32A	40A	50A	65A
R	25.4	25.4	38.1	38.1	38.1	47.6	57.2	76.2	95.3
A	40.0	47.0	52.0	52.0	52.0	66.0	70.0	78.0	91.0
Size	80A	100A	125A	150A	200A	250A	300A	350A	400A
R	114.3	152.4	190.5	228.6	304.8	381.0	457.2	533.4	609.6
A	99.0	115.0	145.0	155.0	195.0	157.8	189.4	296.0	333.0

Tube Size (Inch Size) 45°

Size	1/4"	3/8"	1/2"	3/4"	1"	1-1/2"	2"	2-1/2"	3"	4"	6"
R	20	23	25	30	33	57.2	76.2	95.3	95.3	133.4	228.6
A	38	39	40	49	50	70	78	91	91	107	155

MANUAL WELDING ELBOW 手焊 - 弯头

Pipe Size (A Size)

Unit : mm

Size	15A	20A	25A	32A	40A	50A	65A	80A
A	38.1	38.1	38.1	47.6	57.2	76.2	95.3	114.3
Size	100A	125A	150A	200A	250A	300A	350A	400A
A	152.4	190.5	228.6	304.8	381.0	457.2	533.4	609.6